

## Parts and Installation Instructions Spring Trip Snow Plow Models TM 5.0, TM 6.0 and TM 6.5

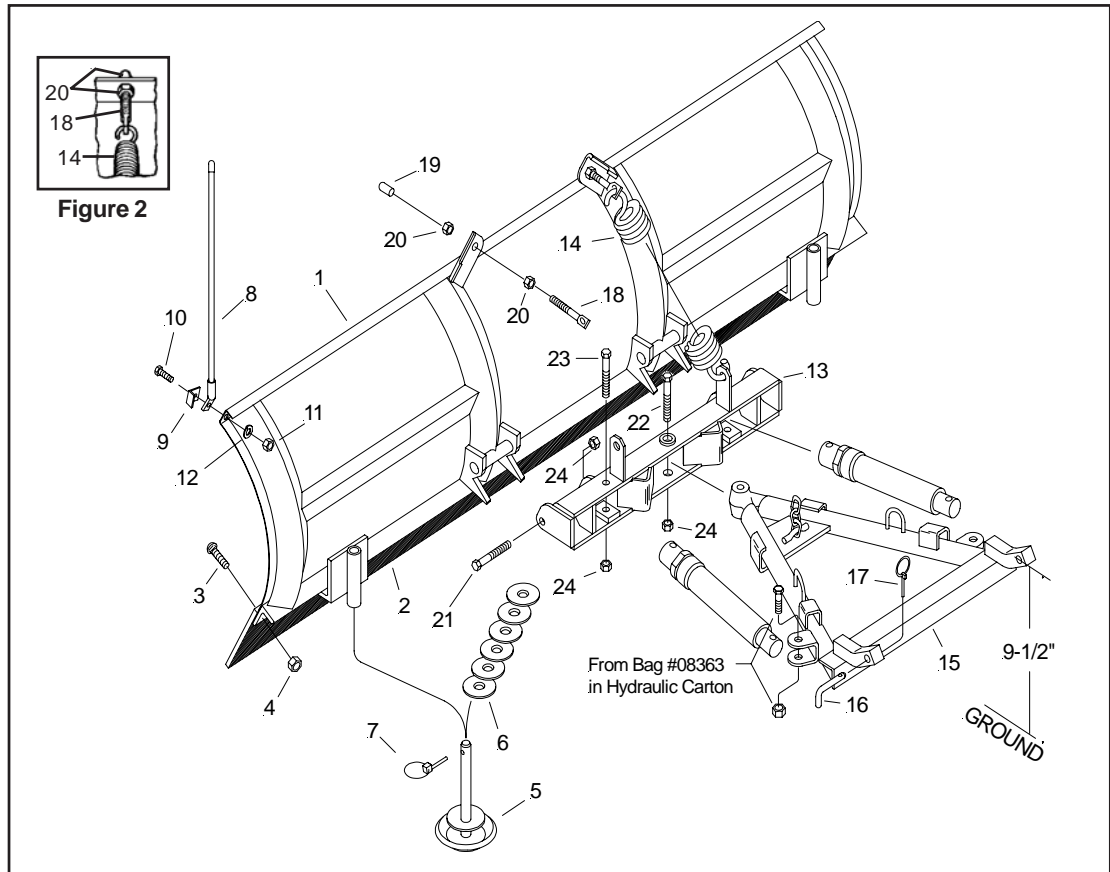

**Note:** TM 5.0 available for export only

Item	Part No.	Qty.	Description
1	-----	1	<b>Moldboard Assembly</b>
2	09294	1	• Cutting Edge (TM 5.0)
2	09104	1	• Cutting Edge (TM 6.0)
2	09100	1	• Cutting Edge (TM 6.5)
2	09105	1	• Cutting Edge (TM 7.0)
3	21943	6	• Bolt C 1/2-13 x 1-3/4" Gr.5
4	20307	6	• Locknut 1/2-13
5	10853	2	• Mushroom Weldment
6	20359	18	• 3/4" Flatwasher
7	22083	2	• Linch Pins
	09916	1	• <b>Snow Plow Marker Kit</b>
8	-----	2	• Snow plow Marker Assy.
9	-----	2	• Clamp
10	-----	2	• Bolt H 1/4-20 x 1" Gr.2
11	-----	2	• Locknut 1/4-20
12	-----	2	• Lockwasher 1/4"

Item	Part No.	Qty.	Description
13	12984	1	Pivot Bar
14	12978	2	Trip Spring
15	-----	1	A-Frame
	08511	1	• <b>Snow Plow Hardware Bag</b>
16	11006	2	•• Hinge Pin
17	22083	2	•• Linch Pin
18	12150	2	•• Eye Bolt
19	07032	2	•• Cap-Eye Bolt
20	20530	2	•• Finish Nut 5/8-11
21a	13598	2	•• Pivot Bolt Pre May 03
21b	13753	2	•• Pivot Bolt
22	13591	1	•• King Bolt
23	20150	2	•• Bolt H 5/8-11 x 4-1/2" Gr.5
24	20309	7	•• Locknut 5/8-11
25	07996	1	•• Cable Tie

**Parts indented are included in the carton, bag or assembly under which they are indented.**

Meyer Products and Diamond Equipment reserves the right, under its continuing product improvement program, to change construction or design details, specifications and prices without notice or without incurring any obligation.

Meyer Products  
18513 Euclid Ave. • Cleveland, Ohio 44112-1084  
Phone 486-1313 (Area Code 216)  
email warranty@meyerproducts.com

Diamond Equipment  
#6 Angell Lane • Damariscotta, ME 04543-9720  
Phone 563-2227 (Area Code 207)  
www.diamondplow.com • email info@diamondplow.com

## INSTALLATION INSTRUCTIONS

- A. Attach pivot bar (13) to Moldboard (1) using pivot bolts (21) coated with chassis lubricant, and locknut (24).
- B. Attach trip springs (14) to pivot bar (13) and moldboard (1) with eye bolts (18), Locknuts (24) and Finish Nut (20). Flat end of eye bolt (18) must be in a vertical position, as shown in Figure 2, to hinge properly when moldboard (1) trips. Proper tension is attained when trip spring (14) coils begin to separate and then tighten top locknut (24) four additional turns. Tighten bottom Finish nut (20) to secure eye bolt (18) in position. Install Eye Bolt Caps (19) over threads. See Figure 1.
- C. Assemble A-Frame (15) to pivot bar (13) using king bolt (22) and locknut (24). Grease king bolt (22) prior to installation.
- D. Install power angling rams with hoses to A-Frame (15) using 5/8-11 x 3-1/4" bolt and locknut (packed in hardware bag 08363 in Electro-Touch carton). Attach piston end of ram to pivot bar (13) using 5/8-11 x 4-1/2" Bolt (23) and locknut (24).
- E. Straighten end of plow markers (8) so they will be vertical after installation. Attach using 1/4-20 x 1" bolt (10), clamp (9), lockwasher (12) and locknut (11).
- F. Secure the moldboard-pivot bar-A-frame assembly to vehicle at the clevis frame using hinge pins (16) and Linch pin (17). Attach lift chain to lift arm allowing sufficient slack to allow moldboard to follow ground contours. Attach loose end of chain with the cable tie (25).