



PARTS & INSTALLATION INSTRUCTIONS E-61H QUICK LIFT® UNITS

PARTS LIST

ITEM	E-61H	QTY	DESCRIPTION	ITEM	E-61H	QTY	DESCRIPTION
1	15726	1	• Sump Base	52	15612	1	• Valve Assy. w/Coup. (12V)
2	15336	1	• Ram Assembly 1-3/4"	53	22445	1	• Coupler, Female Half
3	15206	1	•• Ram	54	22442	1	• Coupler, Male Half
4	15158	1	•• Piston	55	22460	2	• Forged 90 Degree Elbow
5	15219	1	•• Piston Follower	56	15925	1	"A" Solenoid Assembly
6*	15162	1	•• Packing Cup	57	15916	1	•• Coil (12V)
7*	15125	1	•• O-ring 7/16" I.D.	58	15917	1	•• "A" & "B" Cartridge Valve
8	15760	1	•• Spacer	59	15928	1	••• Seal Kit, "A" & "B" Valve
9	20316	1	•• Locknut 1/2-13	60	15926	1	"B" Solenoid Assembly
10	15738	1	• Cover & Seal Assembly	61	15916	1	•• Coil (12V)
11*	05119	1	•• Wiper	62	15918	1	•• "B" Cartridge Valve
12*	15131	1	•• O-ring 3-1/2" I.D.	63	15929	1	••• Seal Kit, "B" Valve
13	15737	1	•• Sleeve	64	15959	1	• Kit- "B" Check Valve
	08473	1	• Pressure Relief Valve Kit	65	-----	1	• "B" Check Valve Nut
14	21805	1	•• Reducer Bushing 1/4-1/8	66	-----	1	•• O-ring
15	21806	1	•• Pressure Relief Valve	67	-----	1	•• O-ring
16	15704	1	• Cylinder Tank	68	-----	1	•• "B" Valve Check Body
17	15205	1	• Cylinder	69	-----	1	•• "B" Valve Check Ball
18	15209	1	• Washer	70	-----	1	•• Ball Holder
19*	15198	1	• O-ring 1-1/8 I.D.	71	-----	1	•• Spring
20*	15131	1	• O-ring 3-1/2 I.D.	72	15987	1	"C" Solenoid Assembly
21*	15163	1	• O-ring 1-15/16 I.D.	73	15916	1	•• Coil (12V)
22	20697	3	• Locknut 5/16-24	74	15958	1	•• "C" Cartridge Valve
23	15709	3	• Stud	75	15930	1	••• Seal Kit "C" Cartridge
24*	21929	5	• Washer, Nyltite 5/16	76	15950	1	Kit Needle Valve (Lower Adj.)
25	22129	1	• Drain Plug w/O-ring 9/16"	77	-----	1	• O-ring
26	15641	2	• Filter Kit 9/16"	78	-----	1	• Needle Valve
27	15619	1	•• Filter	79	-----	1	• Needle Valve Retaining Ring
28	21999	1	•• Plug w/O-ring 9/16"	80	-----	1	• Nut M6 x 1/2" nut
29	15729	1	• Pump	81	15965	1	• Kit Dual PO Check Valve
30	15688	2	• Dowel Pins	82	15944	2	•• Check Valve Assembly
31	15713	1	• Locator	83	15943	1	•• P.O. Pilot Spool
32	15574	1	• Pump Check Valve	84	15999	1	•• Spring
33*	15124	1	•• O-ring 3/8 I.D.	85	15951	1	Kit P.A. Block Filter
34	15354	1	•• Seat	86	15936	1	• Tank Filter
35	15603	1	•• Ball 9/32	87	15938	1	• O-ring
36	15604	1	•• Spring	88	15937	1	• M16 x 1 Filter Cap
37*	15700	1	• O-ring 3/8 I.D.	89	15974	1	• Kit-Crossover Valve
38	15702	1	• Ball Seat	90	-----	1	•• O-ring
39	15699	1	• Relief Valve	91	-----	1	•• O-ring
40*	15701	1	• O-ring "Special"	92	-----	1	•• Body
41	15703	1	• Pump Mounting Plate	93	-----	1	•• O-ring w/Glyd. Ring
42	22119	2	• Bolt 3/8-16 x 3-1/4" Gr. 5	94	-----	1	•• Poppet
43	21083	2	• Star Washer 3/8	95	-----	1	•• Washer
44*	15122	2	• O-ring 1/4 I.D.	96	-----	1	•• Spring
45*	15124	1	• O-ring 3/8 I.D.	97	-----	1	•• Plug
46	15727	1	• Motor - Two Terminal	*	15975	1	•• Seal Kit-Crossover Valve
47	15892	1	• Cover/Motor Mount w/tabs				(includes items 83,84,86)
48	22120	2	• Cap Screw 5/16 x 3-1/4"	98	21826	4	Soc. Head 5/16-18 x 1-1/2"
49	15686	1	• Pump Shaft Seal				
50*	15687	1	• O-ring 4-3/4 I.D.				
51	15966	1	• "A" valve Plug w/o-ring				

Parts indented are included in the carton, bag or assembly under which they are indented.

* Parts included in Master Seal Kit Part No. 15626
Basic Seal Kit Part No. 15707 is included in Master Seal Kit.
Pump Relief Valve @ 2000 ± 50 P.S.I. full flow.
Crossover Relief Valve @ 3800 ± 400 P.S.I. @ 2-1/2 G.P.M. **Non Adjustable**

Meyer Products and Diamond Equipment reserves the right, under its continuing product improvement program, to change construction or design details, specifications and prices without notice or without incurring any obligation.

Meyer Products LLC
18513 Euclid Ave. • Cleveland, Ohio 44112-1084
Phone 486-1313 (Area Code 216)
www.meyerproducts.com • email info@meyerproducts.com



Meyer Products LLC
6 Angell Lane • Damariscotta, ME 04543-4507
Phone 563-2227 (Area Code 207)
www.meyerproducts.com • email info@meyerproducts.com

Exploded View

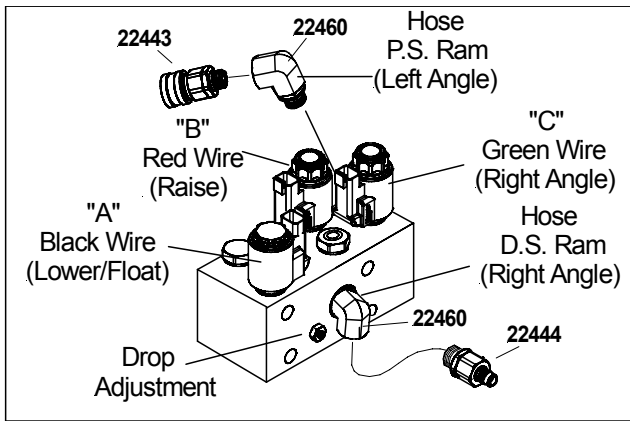

E-61H

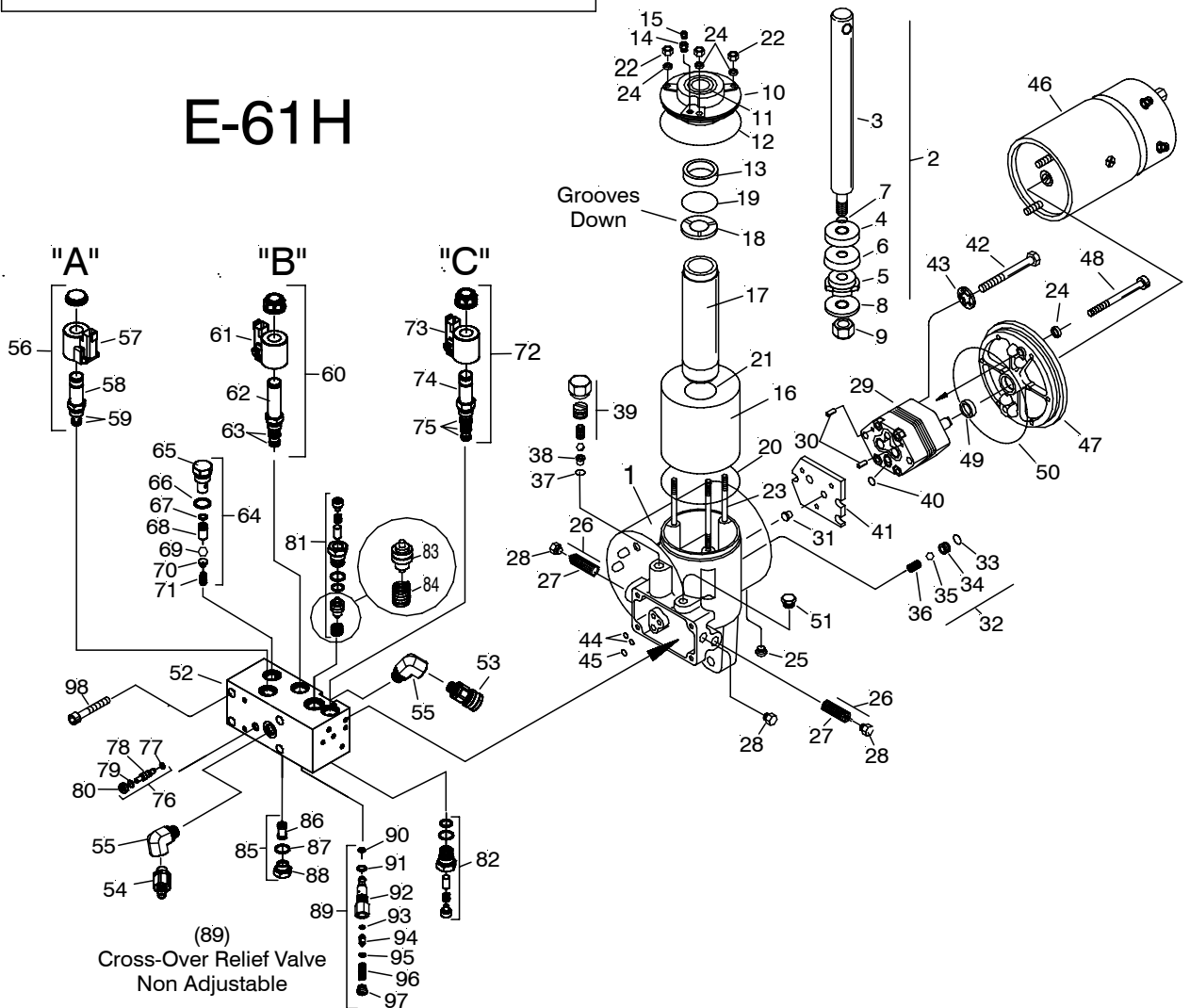

*Parts included in Master Seal Kit Part No. 15626 (E-60 & E-61H)

Basic Seal Kit Part No. 15707

Pump Relief Valve @ 2000 ± 50 P.S.I. full flow.

Crossover Relief Valve @ 3800 ± 400 P.S.I. @ 2-1/2 G.P.M. **Non Adjustable**

GENERAL INFORMATION

Before the Meyer Quik-Lift® unit is disassembled for repairs, make certain that all the maintenance procedures have been checked. Refer to Owner's Manual.

When the unit is to be overhauled, Master Seal Kit Part No. 15626 is required. This Kit contains all necessary Seals for rebuilding. **NOTE: DO NOT REUSE OLD O-RINGS.**

When ordering parts, furnish Type of Unit, Part No., Name and Description.

DISASSEMBLY AND INSPECTION OF UNIT

Drain fluid from unit by removing Pressure Relief Valve (15) or Drain Plug (25). Clamp Sump Base (1) firmly into vise.

1. To disassemble Cover Assembly (10), Cylinder Tank (16), Lift Cylinder (17), and Ram Assembly (2), remove the three Locknuts (22) and Nyltite Washers (24).
2. To disassemble Motor (46), remove motor end cover screws, if needed, exposing motor mounting bolts. Loosen motor mounting bolts; **DO NOT EXTRACT FROM MOTOR.**
Note: Motor end plate to be held in place. Temporarily install two 1/4-20 nuts on the motor mounting bolts to keep motor intact. Remove nuts when reinstalling motor. Remove motor.
3. To disassemble Motor Mounting Plate (47), remove Bolts (48) and Nyltite Washers (24).
4. To disassemble Pump (29) from Sump Base (1), remove Bolts (42) and Starwashers (43).
5. To disassemble Pump Mounting Plate (41), remove Plate and Locator (31).
6. Remove Pump Check Valve (32). (Caution Spring Loaded)
7. To disassemble Valve Block (52) from Sump Base (1), remove Soc. Hd. Screws (98).

SUB ASSEMBLIES - INSPECTION

1. **COVER ASSEMBLY, TANK, RAM & CYLINDER PARTS:**
 - a) Check Cover Assembly (10), Sump Base (1), and Motor Mounting Cover (47) castings for cracks and damage.
 - b) Replace Wiper Seal (11) pressed in Cover (10).
 - c) Replace the Pump Shaft Seal (49) pressed in Motor Mounting Plate (47).
 - d) Inspect Nylon Sleeve (13), Piston (4), the Piston Follower (5) for excessive wear. Replace Packing Cup (6). Inspect Cylinder (17) for scoring and pitting in bore.
 - e) Inspect Ram (3) for nicks and rust.
2. **MOTOR (46)**
Note: Complete Motor Assemblies are only available from Meyer Products.
3. **PUMP (29) - DO NOT at any time disassemble this Pump. This will void the warranty.**
 - a) The damaged pump shaft seal (49) located in the Motor Mounting Plate (47) may be removed by careful extraction with a screwdriver.

CAUTION: Do not score seal bore in mounting cover. Dip new seal (49) in oil with spring facing upward; press into Motor Mounting Plate (47).

4. **BASE (1)**
 - a) Remove Relief Valve (39). Inspect Spring, Ball, Ball Seat (38) and O-Ring (37) for damage.
 - b) Remove and clean the Filter Screen (27) using kerosene and blow out with air.
 - c) Replace 1/4 I.D. O-rings (44) and 5/16 I.D. O-ring (45) from Seal Kit No. 15626.
5. **VALVE BLOCK (52)**
 - a) Remove and clean "A" Solenoid (56) and inspect for external damage.
 - b) Replace O-rings from Seal Kit Part No. 15928 contained in Seal Kit No. 15626.
 - c) To reassemble, carefully guide the Coil (57) over the Valve Cartridge (59) and use the original External Plastic Nut.
 - d) Remove items (61) & (62). Clean "B" Cartridge (62) and inspect for damage. Replace O-rings from Seal Kit No. 15929 contained in Seal Kit No. 15626.
 - e) Remove and clean "C" Solenoid (72) and inspect for damage. Remove Cartridge Valve (74) and replace O-rings and nylon back-up rings from Seal Kit No. 15930 contained in Seal Kit No. 15626. Be certain O-rings and spacers are oriented properly.
 - f) Test all Coils (57, 61 & 73) for electrical continuity. Nominal coil resistance is 8.3 ohms.
 - g) Remove Pilot Check Valves (81) and Piston Assemblies and inspect the Piston for scratches. Replace O-rings from Master Seal Kit No. 15626.
 - h) Remove all parts of Item (89) and inspect for damage. Replace O-rings from Cross-Over Seal Kit No. 15975.
 - i) With parts removed from Valve Block, clean and blow out with air to remove any foreign particles in Block.
6. **UNIT REASSEMBLY**
 - a) Before reassembling, make certain all components and sub-assemblies are clean and free from all dirt and other foreign material.
lubricate all orings with M-1 oil during assembly.
Coat all bolt threads with a anti-sieze lubricant prior to reassembly.
 - b) Motor mounting bolts must be sealed with Permatex or an all weather type sealant.
 - c) **USE NEW SEALS AND M-1 FLUID WHEN REASSEMBLING THE UNIT.**
 - d) Proper fluid level is 1-1/2" below filler hole. It must be checked with Lift Ram fully retracted.

IMPORTANT: Hydraulic Unit is to be stored in the off season with the Lift Ram in the "UP" position.

Meyer Products reserves the right, under its continuing product improvement program, to change construction or design details, specifications and prices without notice or without incurring any obligation.