

Arctic HD & HDXL Poly Blade, Quadrant & A-frame Installation

ARCTIC HD & HDXL POLY BLADE, QUADRANT & A-FRAME INSTALLATION

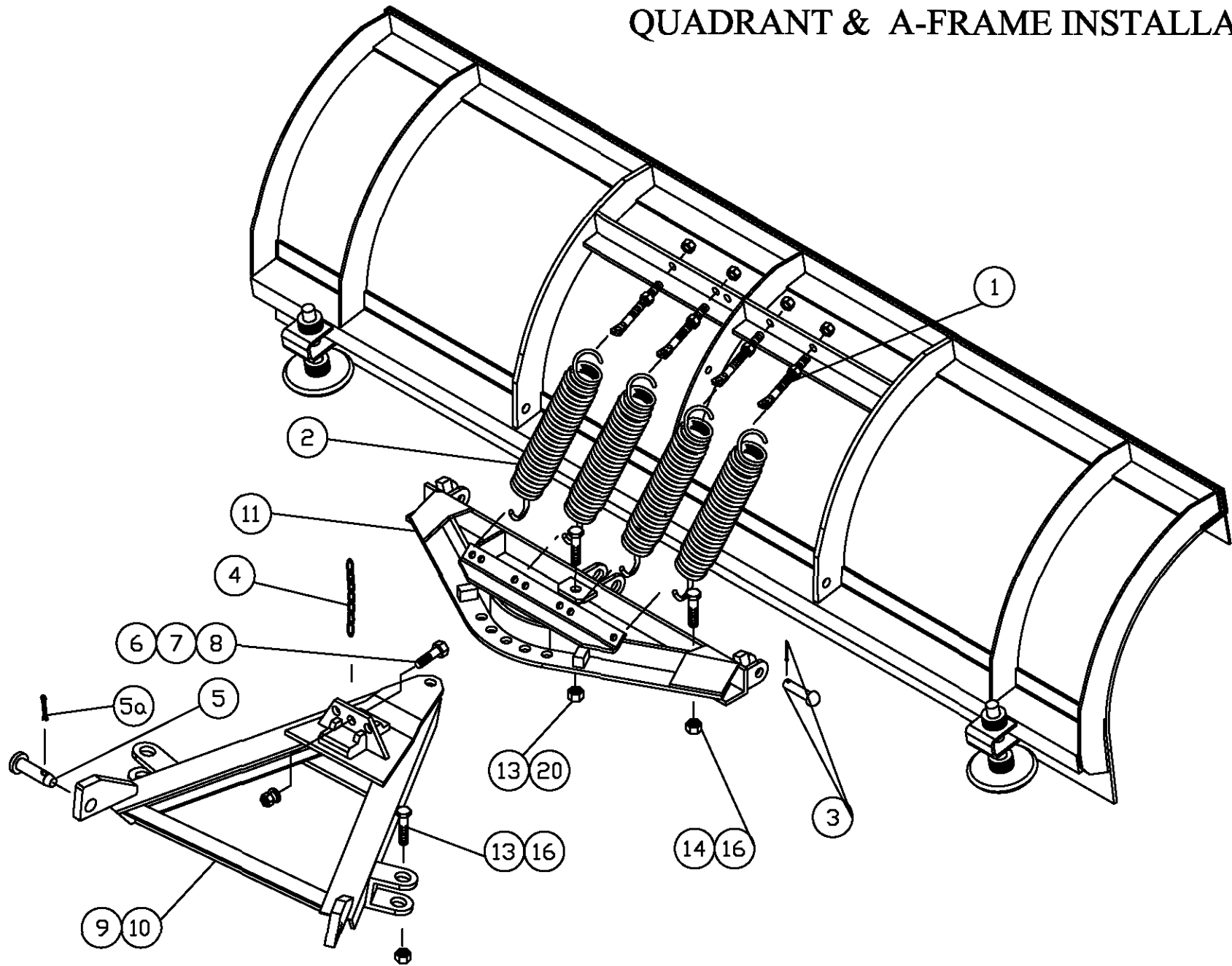

Warning

Do not exceed GVWR or GAWR, including blade and ballast. The rating label is found on the driver side vehicle door corners.

**ARCTIC HEAVY DUTY POLY BLADE 90", 96", 102" & 108",
QUADRANT & A-FRAME**

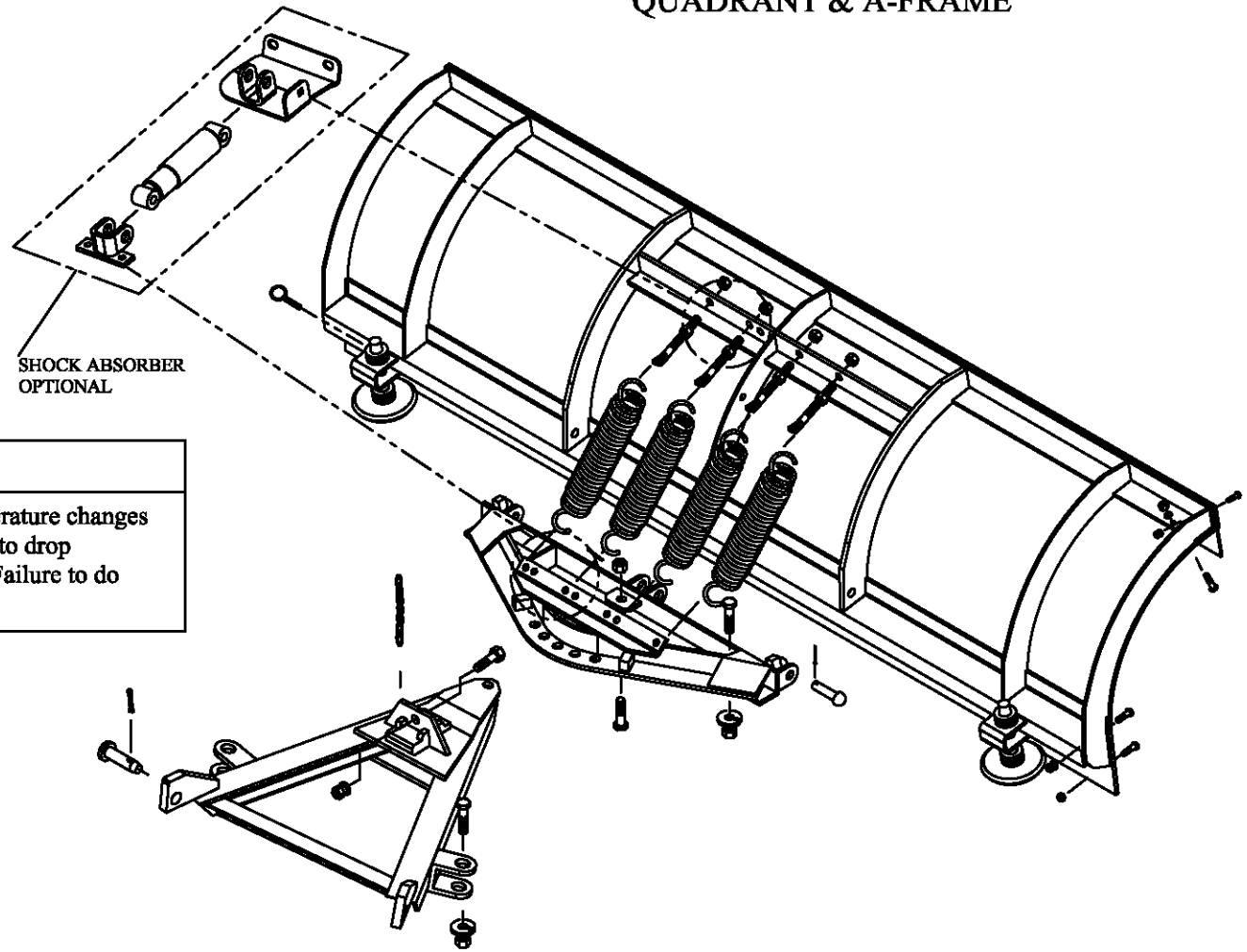

Warning

Lower the blade when the vehicle is parked. Temperature changes could change hydraulic pressure, causing the blade to drop unexpectedly or damaging hydraulic components. Failure to do this can result in serious personal injury.

Warning

Inspect snowplow components and bolts for wear and damage when mounting or removing snowplow and before traveling.

Warning

Keep hands and feet clear of the blade, A-frame and cylinders when mounting or removing the snowplow. Moving or falling assemblies could cause personal injury. Never use a finger to check an alignment. Moving or falling assemblies could crush your finger.

Warning

Do not stand between the vehicle and the blade or within 10' of a moving blade. A moving or falling blade could cause personal injury.

Installation Instructions

1. Lay blade face down on the floor. Attach quadrant (11) to blade by inserting rivets (3) through the holes in the quadrant lugs and blade ribs. Install the centre one first. Secure the rivets with the cotter pins.
2. Take an eye bolt (1) and screw one nut all the way down the thread. Attach spring (2) to the quadrant and the eye bolt, making sure the open end of the spring faces up on the quadrant. Lift the quadrant and insert the eye bolt through the hole on the corresponding hole in the spring plate. Secure the eye bolt with another nut. This will hold the quadrant in an upward position, and ease installation of the remaining three springs and eye bolts.
3. Tighten the eye bolt upper nut until the spring coils just break loose from each other. Secure eye bolts in position by tightening the lower nut against the blade spring plate.
4. Lift chain (4) is attached by inserting a ½" bolt (6) through the last link and in the hole in the A-frame lifting bar. Tighten a ½" nut (7) and lock washer (8) firmly from the face side of the lifting bar.

To attach snowplow to vehicle mount, proceed as follows

1. Position the vehicle such that the A-frame lugs and vehicle mount are in vertical alignment.
2. Hook the chain into the lift channel slot.
3. Actuate lift cylinder slowly. Blade will remain on the ground, but the A-frame will begin to rise. Continue until the A-frame lug holes align with the holes on the vehicle mount.
4. Insert the spreader pins (5) through the holes to attach the A-frame to the vehicle mount. Secure attachment by inserting cotter pins (5a) into the spreader pins.
5. With the control switch in the DOWN position, push the lift channel downward as far as possible and adjust the chain so there are two links of slack.
6. Check the cutting edge clearance. Use a combination of spacer washers until ½" clearance between the ground and cutting edge is achieved. Secure shoes by inserting the lynch pins into the shoe.

Poly Blade Galvanized								
Item	Part Number	Description	Quantity					
			Hardware Kit 52275-01-M	Hardware Kit 52275-02-M	Hardware Kit 52275-03-M	*Power Angling Assembly 52273-M	*Power Angling Assembly 52274-M- GA	
1	50191-M	Eye Bolt Ass'y (eye bolt 5/8" hex nuts)	4					
2	50180-C	Trip Spring	4					
3	50232-M	3/4"X3" Rivet Ass'y (includes cotter pin)	3					
4	55018-02-M	Chain Quik Link		1				
	55018-M	Chain	1	2				
5	53325-A	Spreader Bar Pin	2					
5a	HH-00020-164	Cotter pin	2					
6	HH-00972-090	½-20 x 1.1/2 Hex Head Cap Screw	1		2			
7	HH-00460-002	½-20 Hex Nut	1		2			
8	HH-00457-001	½ Lockwasher	1		2			
9	50656-D-GA	32" A-Frame Galvanized					1	
10	50730-D-GA	28" A-Frame Galvanized				1		
11	52272-M-GA	Quadrant Galvanized				1		
12	CS150-10.00-NRS	Cylinder 1 ½" x 10"				2		

Poly Blade Galvanized							
Item	Part Number	Description	Quantity				
			Hardware Kit 52275-01-M	Hardware Kit 52275-02-M	Hardware Kit 52275-03-M	*Power Angling Assembly 52273-M	*Power Angling Assembly 52274-M- GA
13	HH-00972-152	3/4-16x3.1/4" Hex Head Cap Screw					3
14	HH-00972-153	3/4-16x 3.1/2" Hex Head Cap Screw					2
16	HH-00973-007	3/4-16 Hex Nut Nylon Insert					4
17	HH-00005-008	3/4-16 Castle Nut					1
18	HH-00020-087	1/8Dx2L Cotter Pin					1
19	51188-A	3/4"x2.1/2" Hinge Bolt					1
20	HH-00540-003	3/4"-16 Nylon insert locknut					1

*Power Angling Assembly 52273-M & 52274-M-GA comes assembled from Arctic Equipment.