



PARTS & INSTALLATION INSTRUCTIONS

E-58H, E-68, E-78 & E-88 ELECTRO-LIFT® UNITS

PARTS LIST

ITEM	E-58H, E-78 & E-68, E-88	QTY	DESCRIPTION
1	15869	1	Pump & Motor Assy. (12 volt)
2	15727	1	• Motor - 12 Volt (2 Terminal)
3	15889	1	• Pump Assy.
4	15874	1	••Kit - Pump Relief Valve
5	15870	1	•• Relief Valve Assy.
6	15878	1	•• Plug w/O-Ring
7	08788	1	• Hardware Bag - 15889
8	15973	3	•• Pump Stud
9	20697	3	•• Locknut 5/16 - 24
10*	15875	1	Seal Kit Relief Valve
11	15877	1	Pump Shaft Seal
12	15204	1	Cylinder Tank
13*	15131	1	O-Ring 3-1/2 I.D.
14*	15163	1	O-Ring 1-15/16 I.D.
15*	15198	1	O-Ring 1-1/8 I.D.
16	15738	1	Cover & Seal Assy.
17*	05119	1	• Wiper
18*	15131	1	• O-Ring 3-1/2 I.D.
19	15737	1	• Sleeve
	08473	1	Pressure Relief Valve Kit
20	21805	1	• Reducer Bushing 1/4 x 1/8
21	21806	1	• Pressure Relief Valve
22	15205	1	Cylinder
23	15209	1	Washer (Grooves Down)
24	15761	1	Ram Assembly
25	15206	1	• Ram
26	15158	1	• Piston
27	15219	1	• Piston Follower
28	15760	1	• Spacer
29*	15162	1	• Packing Cup
30*	15125	1	• O-Ring 7/16 I.D.
31	20316	1	• Locknut 1/2-13
32	15980	1	Base & Strainer Assy.
33	15326	1	• Strainer
34	15641	1	• Filter Kit - 9/16"
35	15619	1	•• Filter
36	21999	1	•• Plug w/O-Ring - 9/16"
37	15203	3	Stud
38	15621	1	Baffle
39	21980	2	Retainer Ring
40	15574	1	Pump Check Valve Kit
41*	15124	1	• O-Ring 3/8 I.D.
42	15354	1	• Seat
43	15603	1	• Ball, 9/32
44	15604	1	• Spring
45*	15122	3	O-Ring 1/4 I.D.
46	21999	2	Drain Plug w/O-Ring - 9/16"
47*	15127	1	O-Ring 5/8 I.D.
48*	21929	3	Washer, Nyltite 5/16
49	20697	3	Locknut 5/16 - 24

Meyer Products LLC
18513 Euclid Ave. • Cleveland, Ohio 44112-1084
Phone 486-1313 (Area Code 216)
email • warranty@meyerproducts.com

Meyer Products LLC
6 Angell Lane • Damariscotta, ME 04543-9720
Phone 563-2227 (Area Code 207)
email • warranty@meyerproducts.com

ITEM	E-58H & E-78	E-68 & E-88	QTY	DESCRIPTION
50	15967	15941	1	• Valve Assy. w/Coup. (12V)
51	-----	22445	2	• Coupler, Female Half
51	22445	-----	1	• Coupler, Female Half
52	-----	22442	2	• Coupler, Male Half
52	22442	-----	1	• Coupler, Male Half
53	15925	15925	1	"A" Solenoid Assembly
54	15916	15916	1	•• Coil (12V)
55	15917	15917	1	•• "A" Cartridge Valve
56	15928	15928	1	••• Seal Kit, "A" Valve
57	15926	15925	1	"B" Solenoid Assembly
58	15916	15916	1	•• Coil (12V)
59	15918	15917	1	•• "B" Cartridge Valve
60	15929	15928	1	••• Seal Kit, "B" Valve
61	15959	15959	1	• Kit- "B" Check Valve
62	-----	Not Used	1	•• "B" Check Valve Nut
63	-----	Not Used	1	•• O-ring
64	-----	-----	1	•• O-ring
65	-----	-----	1	•• "B" Valve Check Body
66	-----	-----	1	•• "B" Valve Check Ball
67	-----	-----	1	•• Ball holder
68	-----	-----	1	•• Spring
69	-----	15926	2	"C" & "D" Solenoid Assembly
70	-----	15916	1	•• Coil (12V)
71	-----	15918	1	•• "C" & "D" Cartridge Valve
72	-----	15929	1	••• Seal Kit "C" & "D" Cartridge
73	15987	-----	1	"C" Solenoid Assembly
74	15916	-----	1	•• Coil (12V)
75	15958	-----	1	•• "C" Cartridge Valve
76	15930	-----	1	••• Seal Kit "C" Cartridge
77	-----	15927	1	"E" Solenoid Assembly
78	-----	15916	1	•• Coil (12V)
79	-----	15919	1	•• "E" Cartridge Valve
80	-----	15930	1	••• Seal Kit "E" Cartridge
81	15950	15950	1	Kit Needle Valve (Lower Adj.)
82	-----	-----	1	• O-ring
83	-----	-----	1	• Needle Valve
84	-----	-----	1	• Needle Valve Retaining Ring
85	-----	-----	1	• Nut M6 x 1/2" nut
86	-----	15965	2	• Kit Dual PO Check Valve
87	15965	-----	1	• Kit Dual PO Check Valve
			2	•• Check Valve Assembly
			1	•• P.O. Pilot Spool
		Not Used	1	•• Spring
88	15951	15951	1	Kit P.A. Block Filter
89	15936	15936	1	• Tank Filter
90	15938	15938	1	• O-ring
91	15937	15937	1	• M16 x 1 Filter Cap
92	15974	15974	1	• Kit-Crossover Valve
93	-----	-----	1	•• O-ring
94	-----	-----	1	•• O-ring
95	-----	-----	1	•• Body
96	-----	-----	1	•• O-ring w/Glyd. Ring
97	-----	-----	1	•• Poppet
98	-----	-----	1	•• Washer
99	-----	-----	1	•• Spring
100	-----	-----	1	•• Plug
*	15975	15975	1	•• Seal Kit-Crossover Valve
				(includes items 97,98,100)
101	21826	21826	4	Soc. Head 5/16-18 x 1-1/2"

EXPLODED VIEW

E-58 / E-78

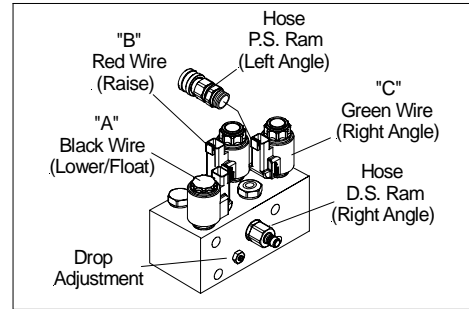
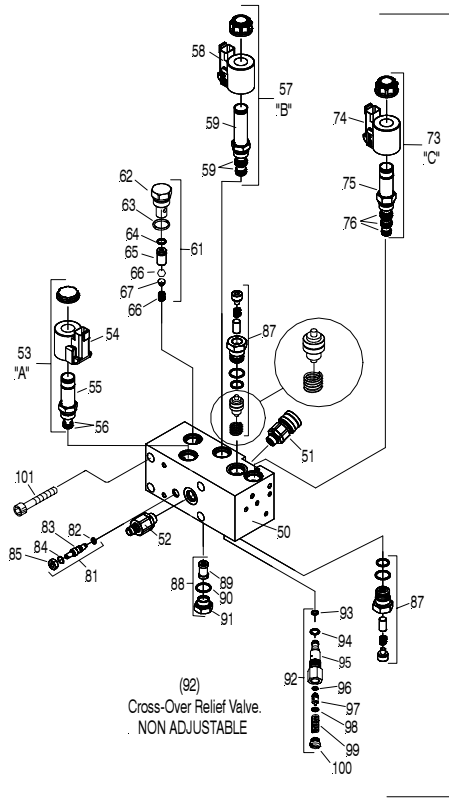

E-68 / E-88

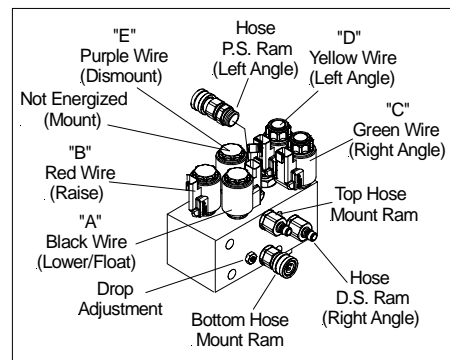
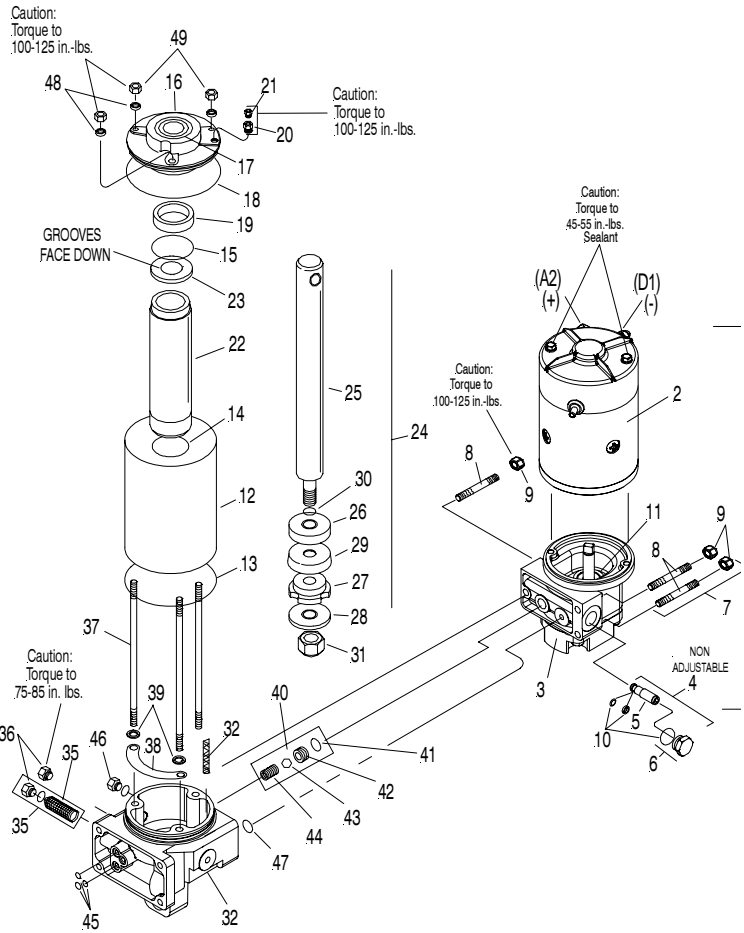
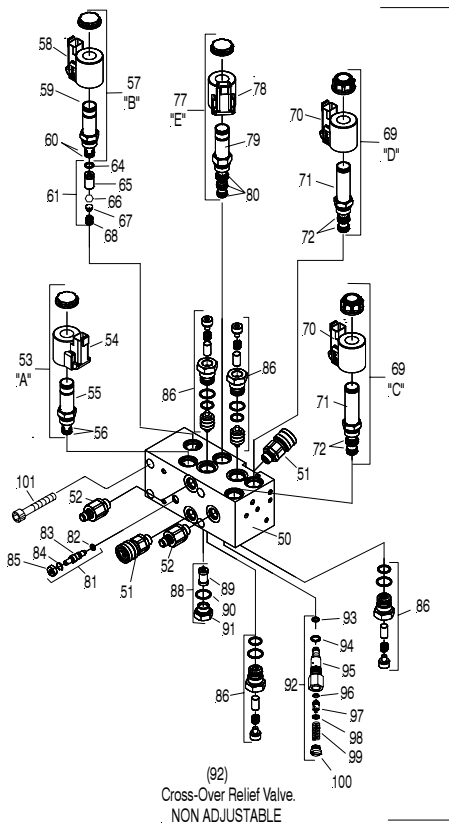

Parts indented are included in assembly under which they are indented.

* Parts included in Master Seal Kit Part No.

15969 (E-58H & E-78),

15978 (E-68 & E-88)

Basic Seal Kit Part No. 15254

Pump Relief Valve @ 2000 ± 50 P.S.I. full flow. **Non Adjustable**

Crossover Relief Valve @ 3800 ± 400 P.S.I. @ 2-1/2 G.P.M. **Non Adjustable**

GENERAL INFORMATION

Before the Meyer Electro-Lift® unit is disassembled for repairs, make certain that all the maintenance procedures have been checked; refer to Owner's Manual. When the unit is to be overhauled, Master Seal Kit Part No. 15969 (E-58H & E-78) or 15978 (E-68 & E-88) is required. This Kit contains all necessary Seals for rebuilding.

These instructions are intended as a guideline for overhaul of an E-58H, E-68, E-78 & E-88 Electro-Lift® unit.

When ordering parts, furnish Type of Unit, Part No., Name and Description.

More detailed information covering principles of Operation, Troubleshooting, Disassembly and Repair are found in Electro-Lift® Service Manual 1-822. This is available for a nominal fee from your Meyer Distributor.

DISASSEMBLY AND INSPECTION OF UNIT

NOTE: DO NOT REUSE OLD O-RINGS.

Drain fluid from the unit by removing Pressure Relief Valve (21) and Drain Plug (46). Clamp Sump Base (32) firmly into vise.

1. To disassemble COVER ASSEMBLY, TANK, RAM & CYLINDER PARTS, remove three Locknuts (49).
2. To disassemble MOTOR from PUMP, loosen Motor mounting bolts, but DO NOT REMOVE bolts from motor housing.
Note: Motor end plate to be held in place. Temporarily install two 1/4-20 nuts on the motor mounting bolts to keep motor intact. Remove nuts when reinstalling Motor to pump.
3. To disassemble Pump from Base, remove three Locknuts (9).
4. To disassemble VALVE BLOCK from BASE, remove Soc. Hd. Screws (101).

SUBASSEMBLIES - INSPECTION

1. COVER ASSEMBLY, TANK, RAM & CYLINDER PARTS:

- a) Check Cover (16), and Base (32) castings for cracks and damage.
- b) Replace Wiper Seal (17) pressed in Cover (16).
- c) Inspect Sleeve (19), Piston (26), the Piston Follower (27), Spacer (28) for excessive wear. Replace Packing Cup (29). Inspect Cylinder (22) for scoring and pitting in bore.
- d) Inspect Ram (25) for nicks and rust.

2. MOTOR - Two Terminal (2)

Note: Complete Motor Assemblies are only available from Meyer Products. The only service parts available are a Brush Kit 15854.

3. PUMP (3)

DO NOT at any time disassemble this Pump. This will void the warranty.

- a) A damaged pump drive Shaft Seal (11) may be removed by careful extraction with a pointed tool. Dip new Seal in oil and with lip down, press into Pump Housing flush to 1/32 inch below face of boss.

4. BASE (32)

- a) Remove (36) and clean the Filter Screen (35) using kerosene and blow out with air. Replace O-rings (35) from Seal Kit No.15978.

5. VALVE BLOCK (48)

- a) Clean "A" & "B" Catridge and inspect for damage. Replace O-rings from Seal Kit No. 15928 or 15929 (E-58H "B") contained in Master Seal Kit No. 15969 or 15978.
- b) Remove and clean "C" & "D" (E-68 & E-88 only) Solenoid and inspect for damage. Replace O-rings and nylon back-up rings from Seal Kit No. 15930 (E-58H & E-78) 15929 (E-68 & E-88) contained in Seal Kit No. 15969 or 15978. Be certain O-rings and spacers are oriented properly.
- c) Test all Coils for electrical continuity. Nominal Coil resistance is 8.3 ohms.
- d) Remove Pilot Check Valves and Piston Assemblies and inspect the Piston for scratches. Replace O-rings from Master Seal Kit No. 15969 or 15978.
- e) Remove all parts of Item (92) and inspect for damage. Replace O-rings from Cross-Over Seal Kit No. 15975.
- f) With parts removed from Valve Block, clean and blow out with air to remove any foreign particles in Block.

6. UNIT REASSEMBLY

- a) Before reassembling, make certain all components and sub-assemblies are clean and free from all dirt and other foreign material.
lubricate all orings with M-1 oil during assembly.
Coat all bolt threads with a anti-sieze lubricant prior to reassembly.
- b) Motor mounting bolts must be sealed with Permatex or an all weather type sealant.
- c) **USE NEW SEALS AND M-1 FLUID WHEN REASSEMBLING THE UNIT.**
- d) Proper fluid level is 1-1/2" below filler hole. It must be checked with Lift Ram fully retracted.

IMPORTANT: HYDRAULIC UNIT IS TO BE STORED IN THE OFF SEASON WITH THE LIFT RAM IN THE "UP" POSITION.

NOTES:

1. * Parts included in Master Seal Kit Part No. 15969 (E-58H & E-78), 15978 (E-68 & E-88)
2. Basic Seal Kit Part No. 15254
3. Pump Relief Valve @ 2000 ± 50 P.S.I. full flow. **Non Adjustable**
4. Crossover Relief Valve @ 3800 ± 400 P.S.I. @ 2-1/2 G.P.M. flow. **Non Adjustable**

Meyer Products LLC reserves the right, under its continuing product improvement program, to change construction or design details, specifications and prices without notice or without incurring any obligation.

