

M673F installation instructions

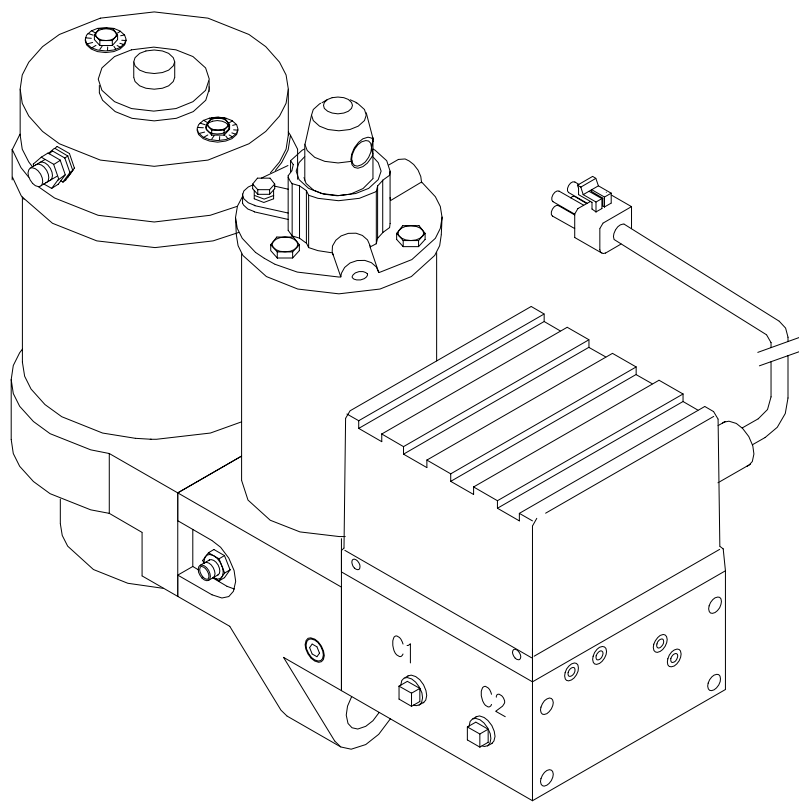

M673F installation instructions

Warning:

- Top of battery needs to be protected. If positive side of battery is accidentally grounded person could be burnt or wiring system can be damaged, or battery gasses could explode causing injuries.
- Disconnect cable from negative battery terminal before start installation.
- Always wear eye protection and protective clothing when working around hydraulic systems.
- Remove jewelry and objects that might conduct electricity while working on power units.
- Fluid under pressure can pierce the skin and enter the bloodstream causing death or serious injury.
- Hydraulic hoses and electrical cables (harnesses) must be tied and routed safely to avoid any damage and pinching (away from hot places, sharp objects etc.).

-Do not use teflon tape on hydraulic fittings as it can easily jam valves and plug the filters in the system

-All electrical connections must be greased with die electrical grease to prevent corrosion

1. Install power unit (1) to lift frame with motor toward curb side of truck.
2. Install colour co-ordinated weather covers on cable and plug assembly (2). Attach red lead to positive motor stud and black lead to the ground motor stud. Liberally coat connections with di-electric grease then slide covers (12)(15) over the eyes on the end of the cables.
3. Mount solenoid (3) to metal surface in engine compartment bending bracket if necessary. Be sure to locate the solenoid so that there is sufficient cable to reach to both the battery cable (5) and the cable and plug assembly (2) on the power unit.
NOTE: Solenoid must be well grounded in order to function properly.
4. Slide weather cover (9) over power (5) and ground (6) cables and route through grille of truck leaving sufficient length to attach to the cable and plug assembly (2). Secure the red power cable (5) to the large terminal on the solenoid and the black ground cable (6) to the negative terminal on the battery.
5. Secure power cable (7) from other large terminal on solenoid to positive terminal on battery.
6. Plug intermediate harness (8) into power unit harness and follow battery cable routing toward firewall. Locate a pass through hole in the firewall near the driver's side of the truck. Route other end of intermediate harness (8) through the hole in firewall and attach control station.

NOTE: A smaller hole in the firewall can be used if the cable is fed into the engine compartment from the cab as the plug at the power unit end is smaller than at the control station end.

7. Attach white wire to ground, black wire to positive side of solenoid and brown wire to small terminal on top of the solenoid.
8. Neatly secure all excess cables and wires using tie straps. Silicone hole in firewall.

Note: Be sure all cables are properly protected from any sharp edges or hot or moving parts.

9. Install swivel end of 29" hose into port C1. Install 90 degree swivel elbow (10) in curbside (CS) angle cylinder @ 1:00. Connect straight end of 29" hose loosely to swivel elbow.
10. Install 90 degree swivel elbow (10) into driver's side (DS) angle cylinder @ 10:00. Connect straight end of 18" hose loosely to 90 degree swivel elbow on cylinder. Connect 90 degree swivel end of 29" hose into port C2.
11. Remove power unit filler plug and fill reservoir with **UNIVIS J13 (HVI 13)** hydraulic oil. Do not use automatic transmission fluid in this system as it may lead to aeration of the oil in very cold weather conditions. Use of fluid other than J13 will void warranty.
12. Manually angle the plow to one side before activating the power unit. This can be easily accomplished as the hose connections are loose at the angling cylinders.
13. Remove the bleeder hole plug (31). Jog the lift switch until no air is seen in the fluid passing through the bleeder hole. Reinstall and tighten the bleeder plug.
14. Jog the angle switch in the direction of the retracted cylinder until no air is seen in the fluid passing through the loose connection. Tighten fittings. Fully extend this cylinder.
15. Jog the angling switch in the direction of the other cylinder until no air is seen in the fluid passing through the loosened connection. Tighten fittings.
16. Refill power unit so that oil level is $\frac{3}{4}$ " from the top of the reservoir. Clean up any spilled oil and check all functions several times making sure there is not excessive foaming in the reservoir. Compress the lift cylinder and double check the oil level. Check for leaks at all fittings and reinstall filler plug. Filler plug only has to be snug. Do not torque closed.

Arctic Equipment Manufacturing Corporation

R04

M673F Power Unit Kit Installation Instructions

52209-05-M M673F Power Unit Kit for Quik-Link Mounting Style/ 52209-06-M M673F Power Unit Kit for Bush Guard Mounting Style			
Item	Part Number	Description	Quant.
1	M673F-01	M673F010-01L27E power unit	1
2	3004665	Cable and plug assembly	1
*3	FP17757	Solenoid	1
5	1306120	63" Power Cable	1
6	13061221	54" Ground Cable	1
7	1306340	22" Battery Power Cable	1
8	FPN0457-SA	Intermediate Harness	1
**9	0203300	Weather Cover for power and ground cable	1
10	HH-00794-003	90 degree swivel elbow	2
11	51003-N	Quick Disconnect (Includes Male & Female)	2
**12	52427-N	Red Terminal Protector	1
14	51002-M	18" Hose Assembly	1
14a	51904-M	29" Hose Assembly	1
**15	52428-N	Black Terminal Protector	1
16	52315-N	Harness dummy plug	1
17	490056-01	½ oz tube die electric grease	1

Note:* Item 3 was part # FP7518

**Items not shown on drawing.

M673F WIRING INSTALLATION

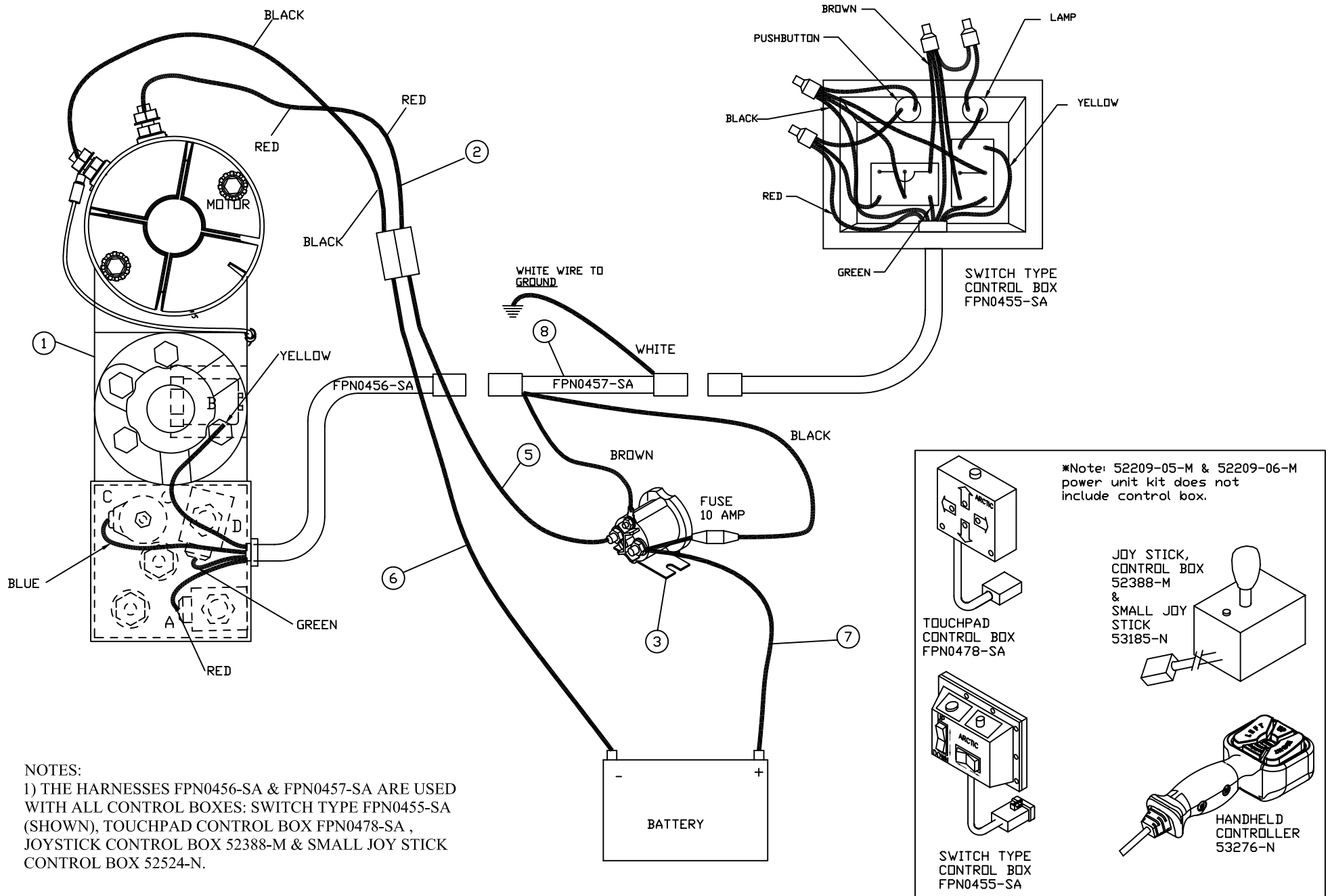

M673F HOSE AND FITTING INSTALLATION

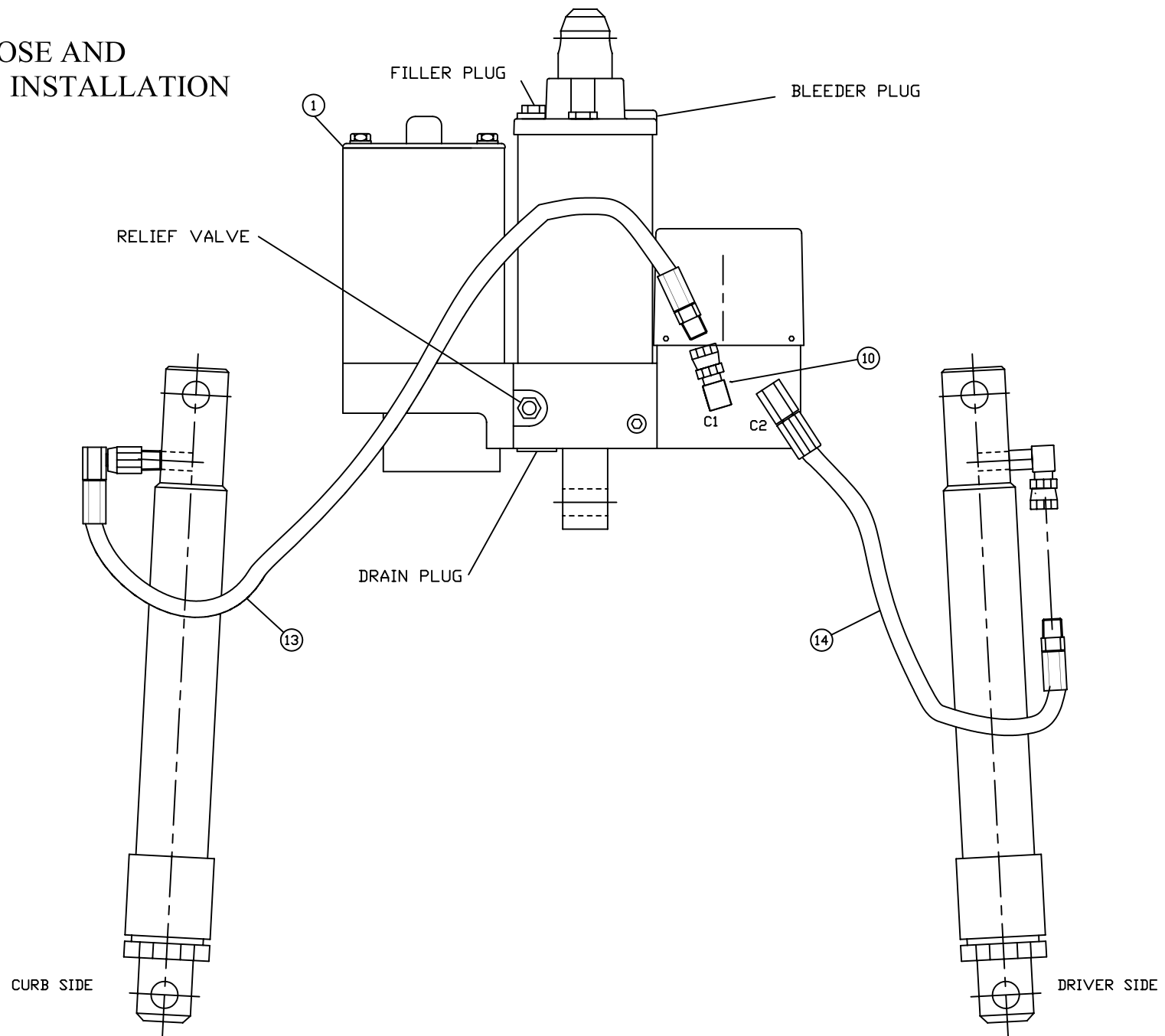

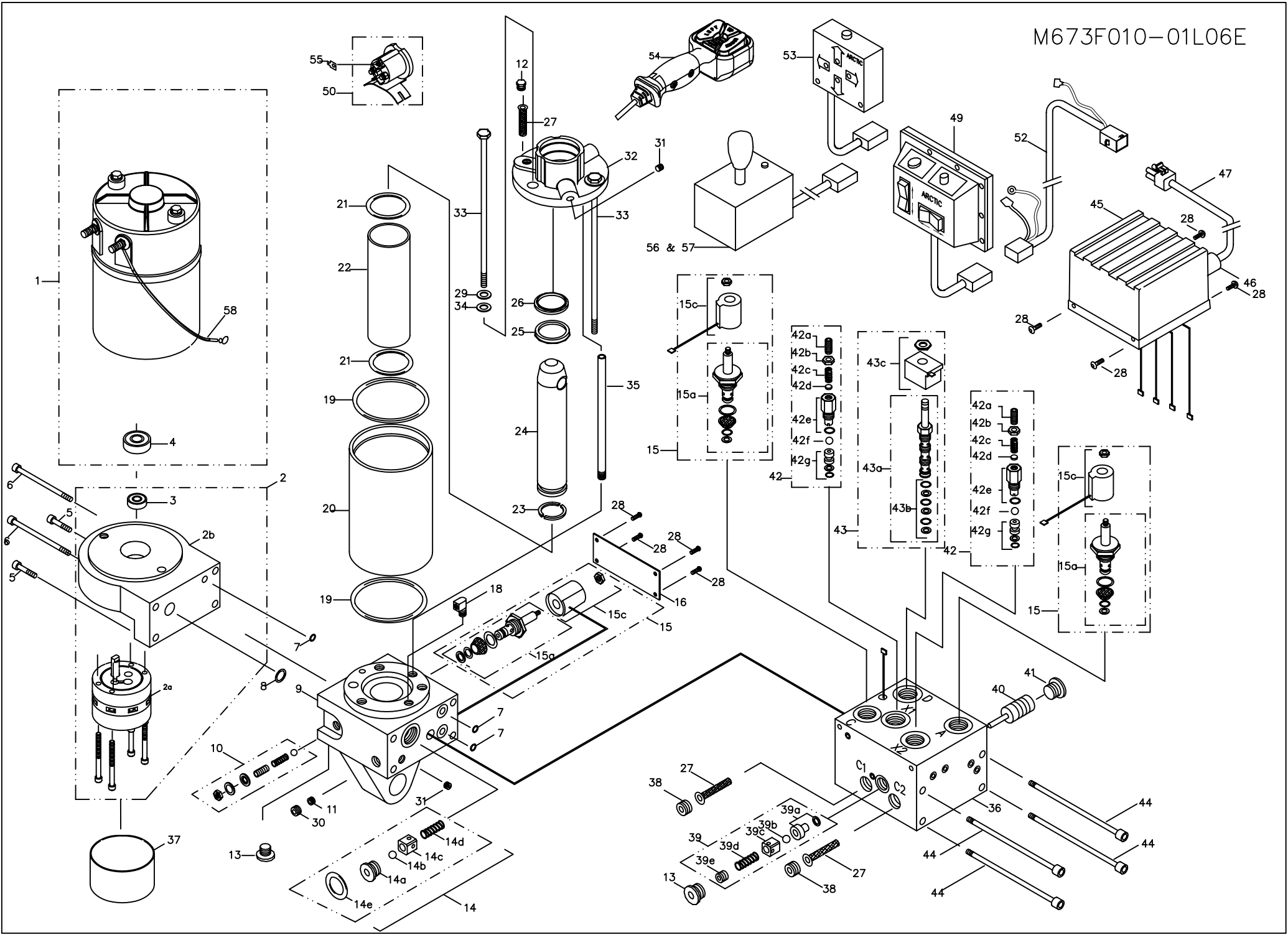

M673F Old- Parts List

Rev	Ref #	Qty	Part #	Description
R2	1	1	FP18442	Electric Motor, 12V DC
R3	1a	1	FP8714	Brush Kit for ISKRA motor (FP18442)
	1b	1	52589-M	Brush Kit for Prestolite Motor (FP8034)
	2	1	FPN0733-SA	Pump and Base Assembly, 03 Gear
R1	2a	1	FPK-12311-250	Modular Pump Kit,03 Gear
	2b	1	FPN0856-SA	Base Ass'y c/w seal
	2c	1	FP7985	Needle Bearing (Pump Shaft to Pump Base)
	3	1	FP2159	Seal, Pump shaft
	4	1	FP2318	Bearing, Motor to Pump Base
	5	2	FPN0582	Screw, SHCS, 1/4-20UNC * 1.0
	6	2	FPN0364	Screw, SHCS, 1/4-20UNC * 4.5
	7	3	FP0117	'O'-Ring, 1/16 * 3/8 ID * 1/2 OD, 2-012,
	8	1	FPN0055	'O'-Ring, 3/32 * 7/16 ID * 5/8 OD, 2-111,
	9	1	FPN0553-SA	Center Block Ass'y (c/w relief valve, check valve, B valve, o-rings)
	10	1	FP7527	Parts Kit, Relief Valve Assembly (c/w washer part #FPN0575)
	11	1	FP4371	Plug, Orifice, 3/64" Hole (1/16-27 NPTF)
	12	1	FPN0585	Plug, Pipe, Hex, 1/4 -NPT
	13	2	FP3276	Plug, Hollow Hex, SAE O-Ring, 9/16-18UNF
	14	1	FPN0558-SA	Check Valve Kit, 5/16 Ball
	14a	1	FPN0557	Seat, 5/16
	14b	1	FP0126	Ball, 5/16
	14c	1	FP2680	Poppet, Ball Retainer
	14d	1	FP0130	Spring
	14e	1	FPN0037	'O'-Ring, 1/8 * 11/16 ID * 15/16 OD, 2-209,
R3	15	3	FP0490	Valve, #8S, 2 Way, 2 Pos, NC Poppet, 12V DC, Single Wire
R3	15a	3	FP10907-D	Valve, #8S, 2 Way, 2 Pos, NC Poppet, Cartridge Only
R3	15c	3	FP10861-D	Coil, 12VDC
	16	1	FPN0343	Center Block Valve Cover
	18	1	FPN0393	Street Elbow, Extruded Brass, 1/8 NPT
	19	2	FPN0358	'O'-Ring, 3-1/4 ID * 3-7/16 OD * 3/32, -152, 90 Duro
	20	1	FPN0346	Reservoir Tube, 3-3/4 OD x 6-3/8 Lg
	21	2	FPN0306	'O'-Ring, 2 ID * 2-3/16 OD * 3/32, -136, 90 Duro
	22	1	FPN0304	Cylinder Tube, 2" OD x 6-3/8 Lg
	23	1	FP5575	Split Ring, Stop 1 1/2 Rod
	24	1	FPN0305	Cylinder Rod, 1-1/2" OD x 10" Lg
	25	1	FPN0356	Rod Seal, 1.5" PolyPack Type B

	26	1	FPN0355	Rod Wiper, U Wiper, 1.5"
	27	3	FP1316	Filter, Finger Screen
	28	8	FPN0546	Screw, Plated, #10-24UNC * 3/8"
	29	3	FP1970	Washer, Plated
	30	1	FP2355	Plug, Pipe, Flush, 1/8 NPT
	31	2	FP7669	Plug, Pipe, Flush, 1/16-27-NPTF
	32	1	FPN0547-SA	Cylinder Head Assembly)c/w wiper, seal and O-rings)
	33	3	FPN0360	Bolt, Hex Head, Grade 8, 3/8-16UNC * 7.5
	34	3	FPN0359	Seal Washer, 3/8
	35	1	FPN0307	Tube, Steel, 5/16 * 6.25 Lg, 1/16 NPTF 1 end
	36	1	FPN0556-SA	Manifold Ass'y (c/w PO check valve and x-over)
	36a	1	52793-m	Manifold Assembly c/w all valves
	*37	1	FPN0719	Plastic Cap
	38	2	FP7624	Screw, Spring Retainer, 9/16-18UNC
	39	1	FP3624	Check Valve Kit
	39a	1	FP2420	Seat, Poppet
	39b	1	FP0126	Ball, 5/16
	39c	1	FP2680	Poppet, Ball Retainer, Check
	39d	1	FP0130	Spring, Light, Check Valve
	39e	1	FP7732	Screw, spring retainer
	40	1	FP0061	Piston, Assembly, Pilot Check
	41	1	FP3274	Plug, SAE #8
	42	2	FP13023	Relief Valve, cross over
	42a	2	FP7899	Screw, S Set, Oval P, 3/8-16UNC * 1.25
	42b	2	FP0386	Nut, Sealing, 3/8-16UNC
	42c	2	FP0147	Spring
	42d	2	FP1288	Shim, Spacer
	42e	2	FP0379	Housing, Adj. Rel. Valve Ball Type
	42f	2	FP0012	Ball, 1/4"
	42g	2	FP0378	Seat, X-Over Rel, Ball Type
R3	43	1	FP10833-D	Valve, #8, 4 Way, 2 Pos, Spool, 12V DC, Single Lead
R3	43a	1	FP11111	Valve, #8, 4 way, 2 Pos, Spool, Cartridge only
	43b	1	FPN0407	Seal Kit, Cartridge Valve
R3	43c	1	FP18835-D	Coil, 10 VDC
	44	4	FPN0365	Screw, SHCS, 1/4-20UNC * 4.25
	45	1	FPN0339	Manifold Valve Cover, Front Mount Plow Unit
	46	1	FP1414	Fitting, Plastic Strain Relief, 1/2" cord
	47	1	FPN0456-SA	Harness, Valve Section End
	48	4	FPN0002	Connector, Panduit
	49	1	FPN0455-Sa	Control Station, Rocker Switch

R4	50	1	FP17757	Solenoid, 12 VDC, 3 Pole, Grounded Coil
	52	1	FPN0457-SA	Harness, Center Section
	53	1	FPN0478-SA	Control Box Assembly, Touchpad
	54	1	53282-M	New Handheld controller
	55	1	FP3414	Terminal, #10 Stud Tab
	56	1	52388-M	Joystick, Control Box Assembly
	57	1	53186-M	Small Joystick Assembly
	58	1	53330-A	Motor to Base Ground Wire

- R1: Cap FPN0719 is included with pump modular kit FPK12311-250 & it is not included with pump base assembly FPN0733-SA

- R2: FP18442 replaces FP8034

R3:

- FP0490-D was FP0490
- FP10907-D was FP0307 *note: if Deltrol cartridge with 3/8 stem FP0307 is replaced with Deltrol cartridge with 1/2 stem FP10907-D, coil must also be replaced with FP10861-D
- FP10861-D was FP0496 *note: If coil FP0496 is replaced with FP10861-D, Deltrol cartridge with 3/8" stem must also be replaced with Deltrol 1/2 stem FP10907-D
- FP7249-D was FP7249
- FP0679-D was FP0679 *note: If Parker cartridge FP0679 is replaced with Deltrol cartridge FP0679-D, Parker coil must also be replaced w/ Deltrol coil FP18835-D
- FP18835-D replaces FP10977
- FP11111 replaces FPN0406 *note: if Parker cartridge FPN0406 is replaced with Deltrol Cartridge FP11111, Parker coil FPN0408 must also be replaced with Deltrol coil FP18835-D
- FP10833-D replaces FPN0352
- R4: Fp17757 replaces FP7518